

T-slot
UNI 5531
DIN 508

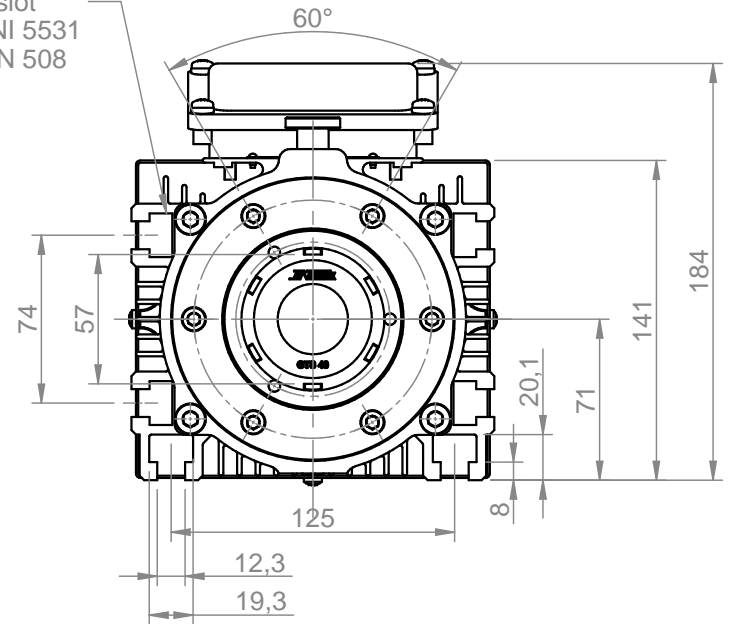

Power [kW] 4.0	Duty Cycle S1	Base speed [rpm] 3000	Base freq. [Hz] 50	Base voltage Δ [V] 220	Absorb. Δ [A] 15.2	Base voltage Y [V] 380	Absorb. Y [A] 8.8
Power [kW]	Duty Cycle	Base speed [rpm]	Base freq. [Hz]	Base voltage Δ [V]	Absorb. Δ [A]	Base voltage Y [V]	Absorb. Y [A]
Min speed [rpm] 3000		Max speed [rpm] 6000		Max freq. [Hz] 100	Protection IP54	Ins. Cl. F	Part number on nameplate COM71800354
Balancing according to ISO 1940 - G2.5 @ 6000 rpm		Balancing type Full Key		tool type 	tool type 	Peso / weight 31.80 kg	Title 7180-C-2DB-P-ER40-RH

TEKNOMOTOR

Teknomotor S.r.l.
Via Argenege 31, I-32038 Quero Vas (BL)
www.teknomotor.com

rev. n° 00	description Emissione			date 20/01/2017	signature D. Bottarel	Customer Catalogo	Drawing code COM71800354
Tolleranze non quotate: UNI EN 22768 fH Smussi non quotati: 0.5 mm Rugosità secondo UNI ISO 1302							

drawn - date E. Gaspari - 20/01/2017	approved - date S. Perli - 20/01/2017	checked - date S. Perli - 20/01/2017	sostituisce il sostituito dal	foglio / sheet 1 / 1	scala n.d.		A4
--	---	--	----------------------------------	--------------------------------	----------------------	--	-----------