

1

2

3

4

5

6

RevNo	Revision note	Date	Signature	Checked
-------	---------------	------	-----------	---------

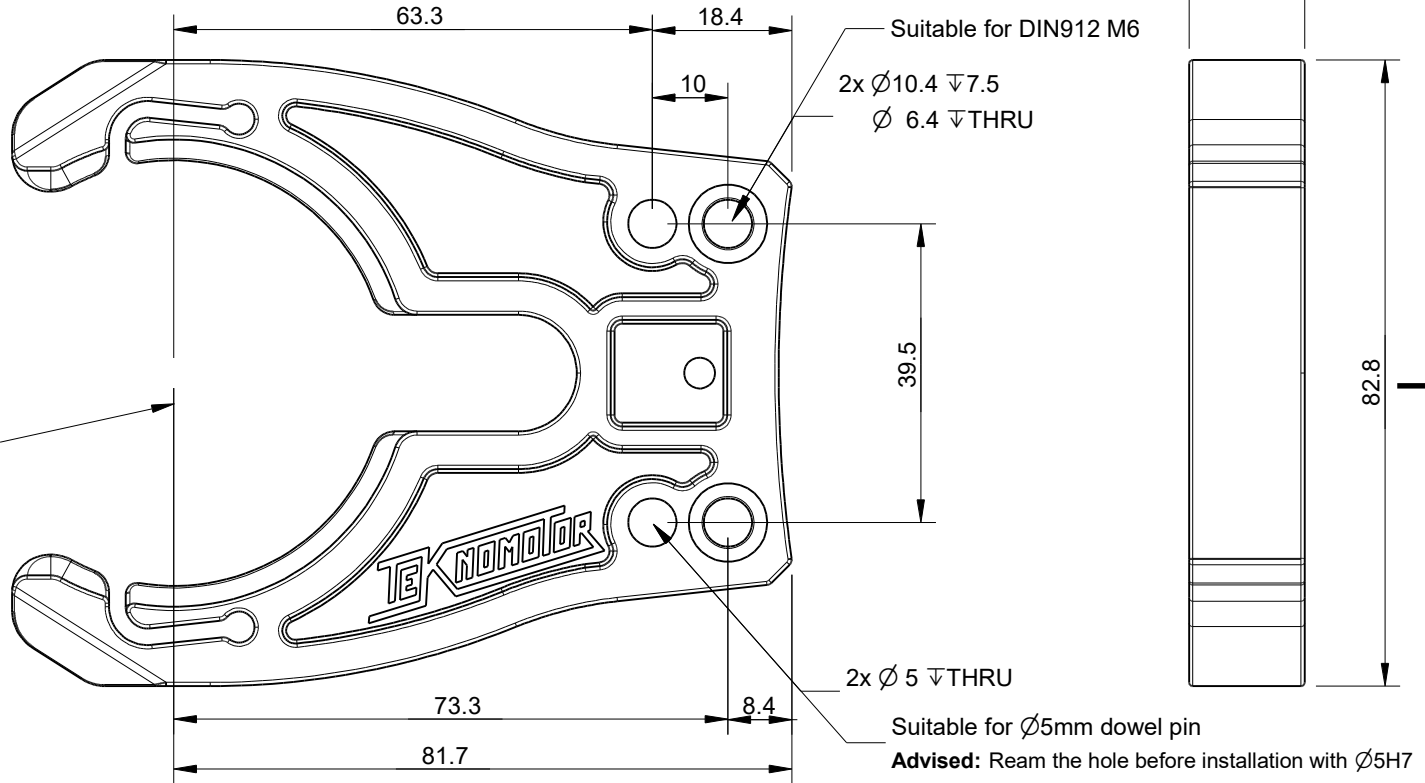
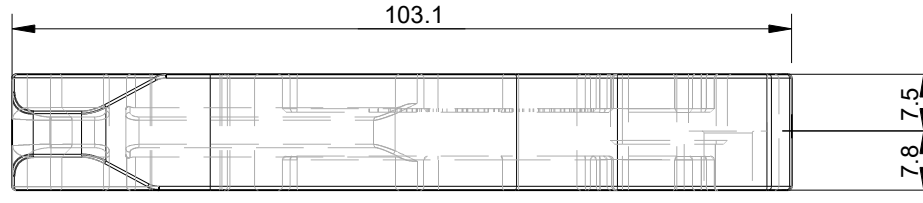
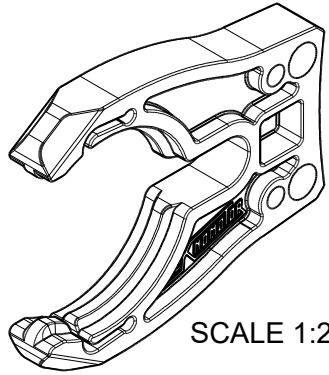

Warning: The dimensions could alter slightly, due to the injection molding manufacturing process

Units	mm
Tolerances	± 0.2 mm unless otherwise specified
Material	PA 6/Nylon 6
Colour	Dark Grey

Itemref	Quantity	Title/Name, designation, material, dimension etc	Article No./Reference
Drawn by Cas Jansen	Checked by Kevin Damen	Approved by - date 7-1-2021	File name Date 7-1-2021 Scale 1:1

3753

www.damencnc.com

3753 TeknoMotor Toolholder Fork HSK63F	Edition	Sheet 1 OF 1
--	---------	-----------------

1

2

3

4

5

6