

1

2

3

4

5

6

RevNo	Revision note	Date	Signature	Checked
-------	---------------	------	-----------	---------

A

A

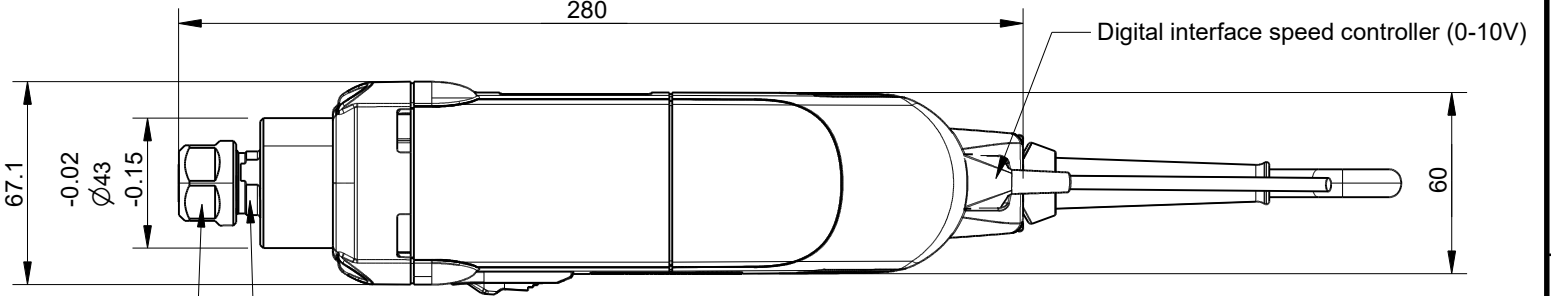
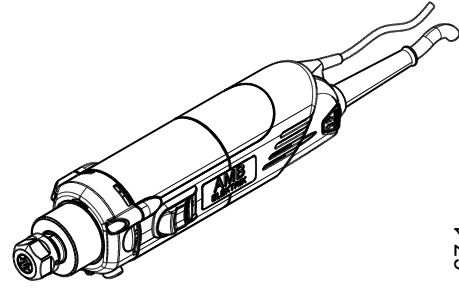

SCALE 1:5

Wrench size 25
Use DamenCNC Wrench 25 - 30 mm (5277)

Wrench size 19

Digital interface wiring		
Power supply	Brown	10-26VDC
Ground	White	0VDC
Speed control	Green	0-10VDC

B

B

Ground cone and precision collet system ER16
with balanced clamping nut for higher concentricity

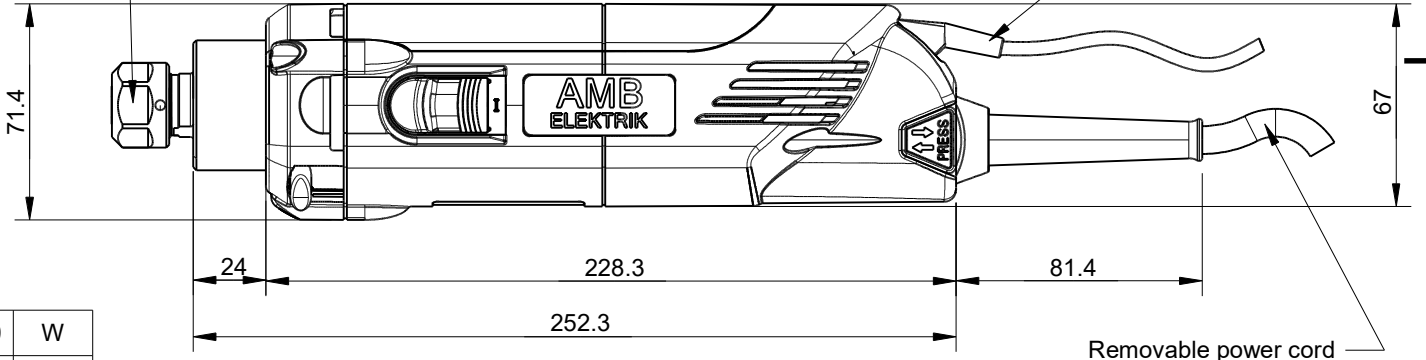

C

C

Power input	1050	W
Power output	600	W
Speed range	3500-25000	RPM
Speed controller	Digital interface (0-10V)	-
Collet system	ER16 (Ø8mm included)	-
Clamping collar	Ø43	mm
Motor weight	1.7	kg
Voltage input	230	VAC

Units	mm
Tolerances	± 0.2mm unless otherwise specified

Itemref	Quantity	Title/Name, designation, material, dimension etc			Article No./Reference	
Drawn by Cas Jansen	Checked by Rutger Schuit	Approved by - date 1-12-2020	File name	Date 1-12-2020	Scale 1:2.5	

D

D

5111

www.damencnc.com

5111	AMB (Kress) 1050 FME-P DI Digital Interface (230VAC)	Edition	Sheet 1 OF 1
------	---	---------	-----------------

1

2

3

4

5

6