

1

2

3

4

5

6

4 x m2.5x12 Bolts DIN912 12.9  
(1.2Nm Tightening Torque)

RevNo    Revision note

Date

Signature

Checked

A

A

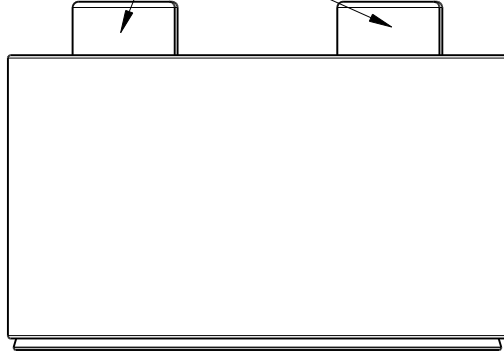

B

B

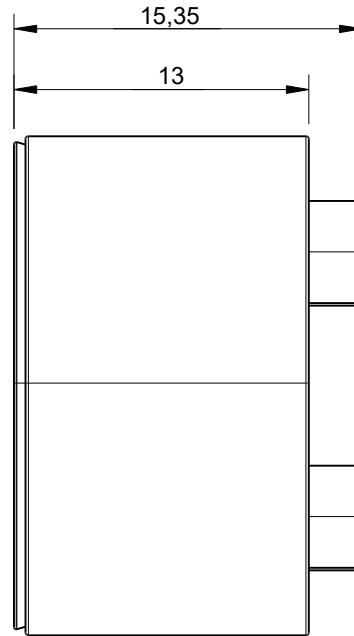

C

C

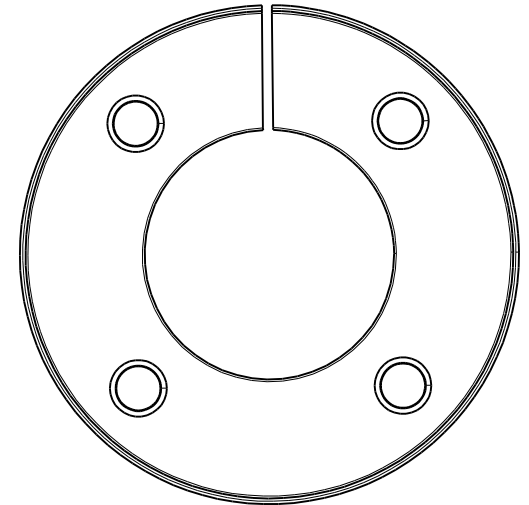
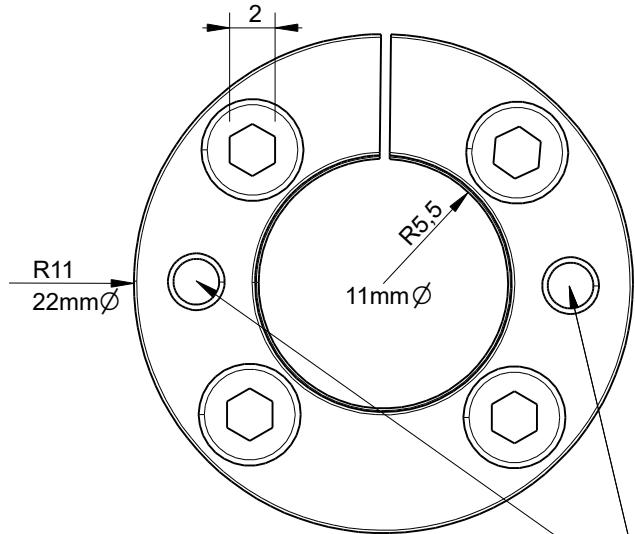

D

D

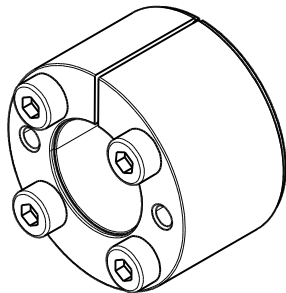

Remove the 4 bolts, and screw 2 back in these threads to release the cone clamping

Itemref	Quantity	Title/Name, designation, material, dimension etc	Article No./Reference		
Drawn by Kevin Damen	Checked by	Approved by - date	File name	Date 4-1-2020	Scale 3:1
			5146	Edition	Sheet 1 OF 1

1

2

3

4

5

6