

1

2

3

4

5

6

RevNo	Revision note	Date	Signature	Checked
-------	---------------	------	-----------	---------

A

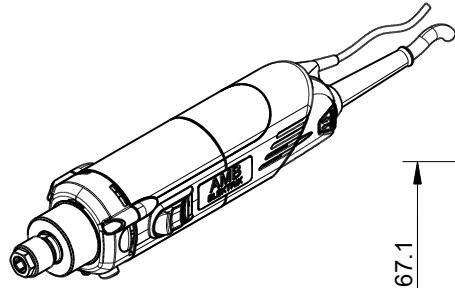

SCALE 1:5

Wrench size 17  
Use AMB (Kress) Wrench 17mm (1413)

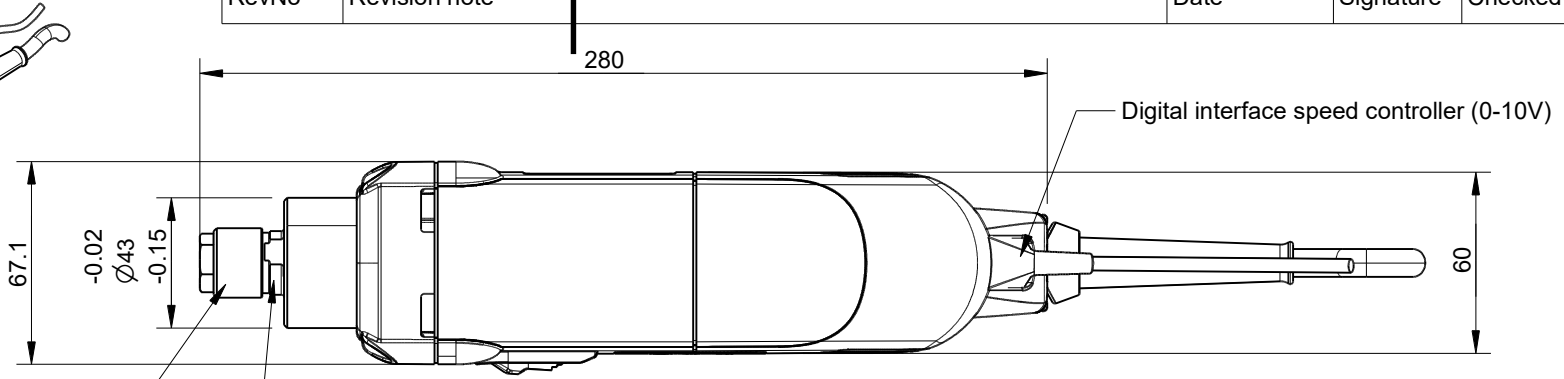

Wrench size 14

Digital interface wiring		
Power supply	Brown	10-26VDC
Ground	White	0VDC
Speed control	Green	0-10VDC

B

B

Standard AMB collet system

Removable power cord

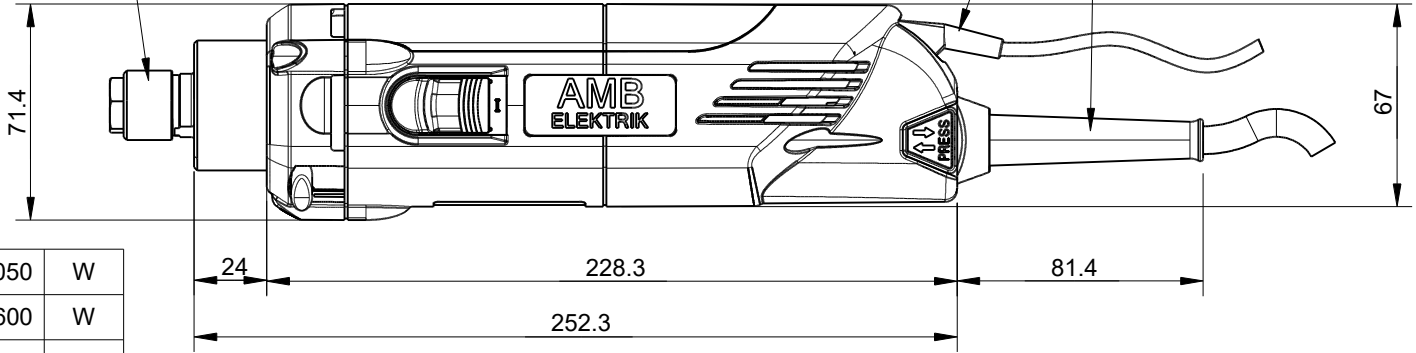

C

C

Power input	1050	W
Power output	600	W
Speed range	3500-25000	RPM
Speed controller	Manual knob (6 positions)	-
Collet system	AMB standard (Ø8mm collet inc.)	-
Clamping collar	Ø43	mm
Motor weight	1.7	kg
Voltage input	230	VAC

Itemref	Quantity	Title/Name, designation, material, dimension etc			Article No./Reference	
Drawn by Cas Jansen	Checked by Rutger Schuit	Approved by - date 5-1-2021	File name	Date 26-10-2021	Scale 1:2.5	

D

D

Units	mm
Tolerances	± 0.2mm unless otherwise specified

# 5747

## www.damencnc.com

5747 AMB (Kress) 1050 FME-1 DI Digital interface (230VAC)	Edition	Sheet 1 OF 1
---	---------	-----------------

1

2

3

4

5

6