

1	2	3	4	5	6
RevNo	Revision note			Date	Signature
					Checked

Including AT-5 25mm Wide belt, and the pulleys prepared for mounting a NEMA 34 stepper motor with a 14mm diameter shaft

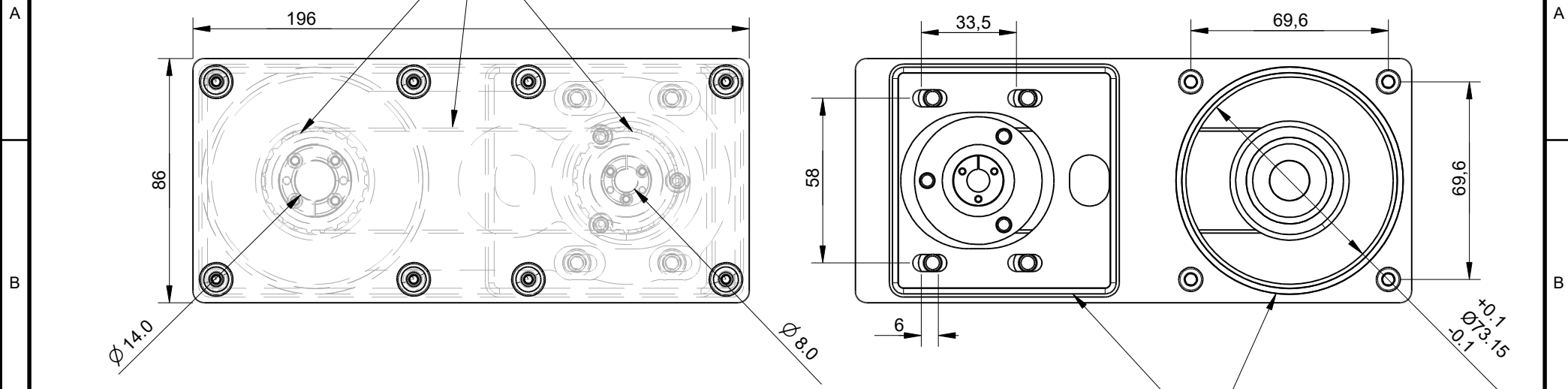

Including all the O-rings to make the gearbox dustproof

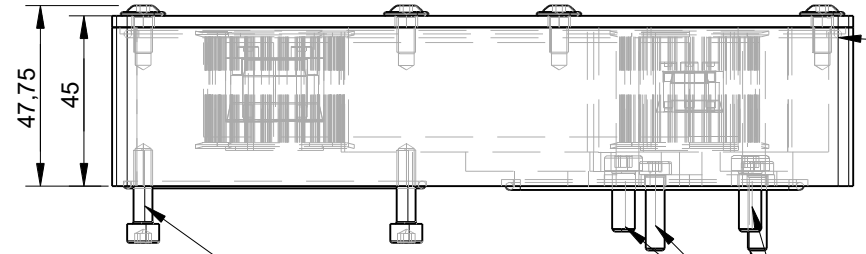

Including M5x20 bolts to attach a NEMA 34 stepper motor

Including the correct bolts to mount to DamenCNC part numbers 4228,4229 and 4230 DCNC Router Z-axis Ballscrew R=XXXX

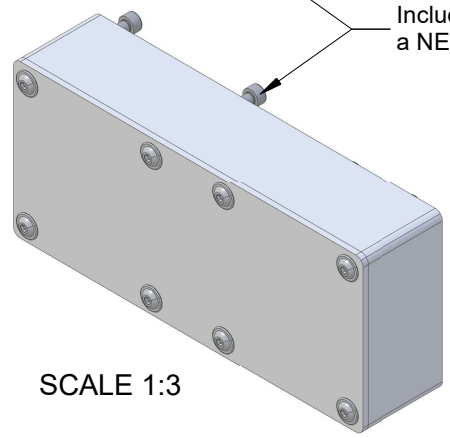

SCALE 1:3

Units: mm Tolerances: +/-0.1mm

Itemref	Quantity	Title/Name, designation, material, dimension etc			Article No./Reference	
Drawn by Kevin Damen	Checked by	Approved by - date	File name	Date 10-1-2024	Scale 1:2	

6470

www.damencnc.com

6470 Timing Belt Gearbox i 1:1 DIY-set for DCNC Router Z-axis Ballscrew			Edition	Sheet 1 OF 1
---	--	--	---------	-----------------