

DamenCNC

**Micro step
Stepper motor
System board
HP5056**

DamenCNC
Louis Pasteurweg 17
2408 AH Alphen aan den Rijn

E-Mail: kpdamen@damencnc.com
Homepage: <http://www.damencnc.com>



Safety Instructions



The stepper motor system board is a module without own functions and is meant to build into a complete system unit. Use of the system board can cause electromagnetic distortion.

The construction need always be done in a way as described in appendix A and need to be done by trained people. The intensity of failures depends on multiple factors such as cable length between motor and system board, power current, stepper engine rotations, cable quality etc. Therefore you need to follow the instructions of EN 89/336 (EMV law), and the installation need to be tested in normal conditions.

You always need to take off the power before you make any connection or disconnection to the system board. After power off you have to wait at least 10 seconds before all condensators are discharged.

When no stepper motors are connected at the connectors of the system board in this case the full stepper motor power is on the connectors.

Up to 50 Volt can be on the connectors.

Functions

- 15 settable micro step possibilities
- Extreme soft engine running
- Less heat development for motor and system board
- Optocoupler connection
- Automatic power reduction at sleep
- Protection against power shortage and over voltage
- Power settings via DIP switches

Protect functions

- The over voltage protection is activated by a power of 52 V and higher and the red LED will lit. When the power is less then 20V this function to protect the system board is not valid anymore.
- Protection against power shortage between coil and ground (GND), when this is activated the red LED will lit.
- De over voltage protection feature prevents by power shortage a distortion of the system board.

Power setting with DIP switches 1-3

Motor power (peak)	Motor current (RMS)	SW 1	SW 2	SW 3
1,4	1,0	OFF	OFF	OFF
2,1	1,5	ON	OFF	OFF
2,7	1,9	OFF	ON	OFF
3,2	2,3	ON	ON	OFF
3,8	2,7	OFF	OFF	ON
4,3	3,1	ON	OFF	ON
4,9	3,5	OFF	ON	ON
5,6	4,0	ON	ON	ON

Select the right settings and see the power instructions of your stepper motor. If the value of your stepper motor is not in the table, use the value which is close to the original value given by the manufacturer of your stepper motor. Select a lower value for a softer run of the stepper motor and for less heating of the stepper motor.

Automatic power reduction

To prevent heating of the stepper motor and system board, it is possible to activate automatic power reduction via dip switch 4, set dip switch SW 4 OFF. When the stepper motor is not in use, the power to the stepper motor will be reduced after 1 second when the last step pulse is made and will be reduced with 50%. Before the next step this reduction will be terminated automatically.

Micro step settings with DIP switches 5-8

Micro steps	Steps / rotations for 1,8° motors	SW 5	SW 6	SW 7	SW 8
2	400	OFF	ON	ON	ON
4	800	ON	OFF	ON	ON
8	1600	OFF	OFF	ON	ON
16	3200	ON	ON	OFF	ON
32	6400	OFF	ON	OFF	ON
64	12800	ON	OFF	OFF	ON
128	25600	OFF	OFF	OFF	ON
5	1000	ON	ON	ON	OFF
10	2000	OFF	ON	ON	OFF
20	4000	ON	OFF	ON	OFF
25	5000	OFF	OFF	ON	OFF
40	8000	ON	ON	OFF	OFF
50	10000	OFF	ON	OFF	OFF
100	20000	ON	OFF	OFF	OFF
125	25000	OFF	OFF	OFF	OFF

Connections of system board P1 and P2

Signal connections

Signal	Function
PUL + (+5V)	Pulse step. With an increasing set a step will be deleted. Pulse width must be $>1,2\mu\text{S}$.
PUL - (PUL)	Pulse step. Wit an increasing set a step will be deleted. Pulse width must be $>1,2\mu\text{S}$.
DIR + (+5V)	Direction signal. High or low level. Direction signal must be $2\mu\text{S}$ before the next step pulse
DIR - (DIR)	Direction signal. High or low level. Direction signal must be $2\mu\text{S}$ before the next step pulse.
ENA + (+5V)	Enable signal. With this signal the system board can be switched power less (i.e. Emergency switch) Normally here is a high peak or unused.
ENA - (ENA)	Enable signal. With this signal the system board can be switched power less (i.e. Emergency switch) Normally here is a high peak or unused.

Engine power and motor connections

Pin Nr.	Signal	Function
1	GND	Motor power Min (Ground)
2	+ V	Motor power + Max. 50V
3 and 4	Phase A	Motor coil Phase A (A+ and A-)
5 and 6	Phase B	Motor coil Phase B (B+ and B-)

Polarity of motor power (plus and minus) may not connect in a wrong way; otherwise the system board will be distorted.

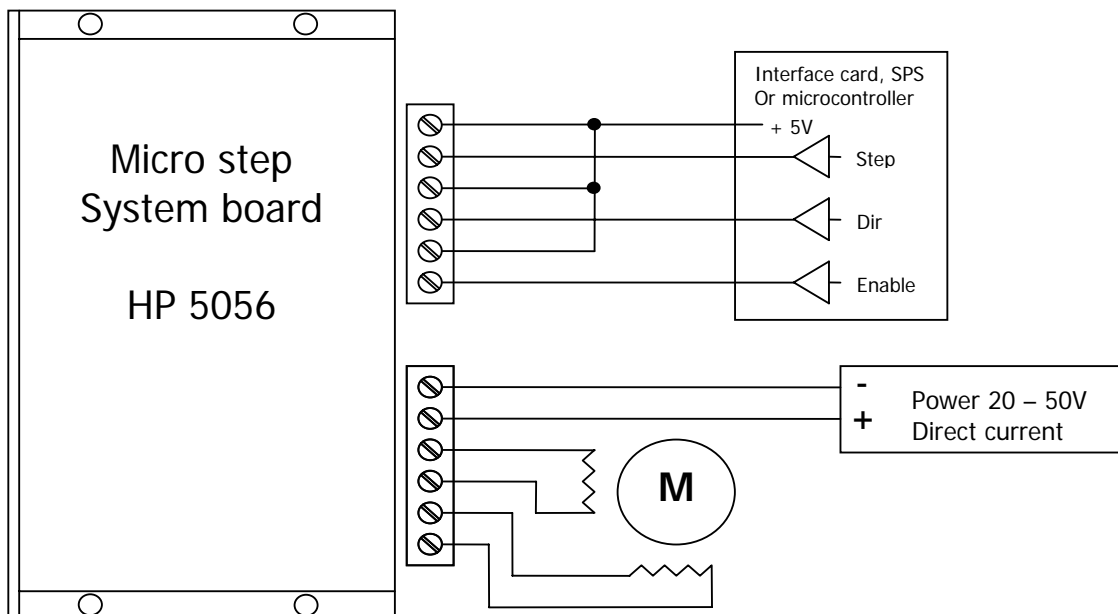

Appendix A

Electromagnetic distortion

System board, stepper motor and cable are a source for electromagnetic distortions. Follow the instructions of EN 89/336 norm, it is necessary to watch that the installation is build in a way as described in following picture. See also picture PIC.1.

- System board, power supply and all necessary electronic components need to build in a joint metal housing which has an earth connection.
- Earth connections connection need to be made short and low resistant.
- The connection of cable, system board and stepper motor need to be connected to earth and must be made with a cable with earth shield. The shield of the connecting cable must be mounted at the metal housing, to transfer any earth potential.
- A power filter needs to be placed between power cable and transformer. The power filter needs to be placed close to the power source in the metal housing.

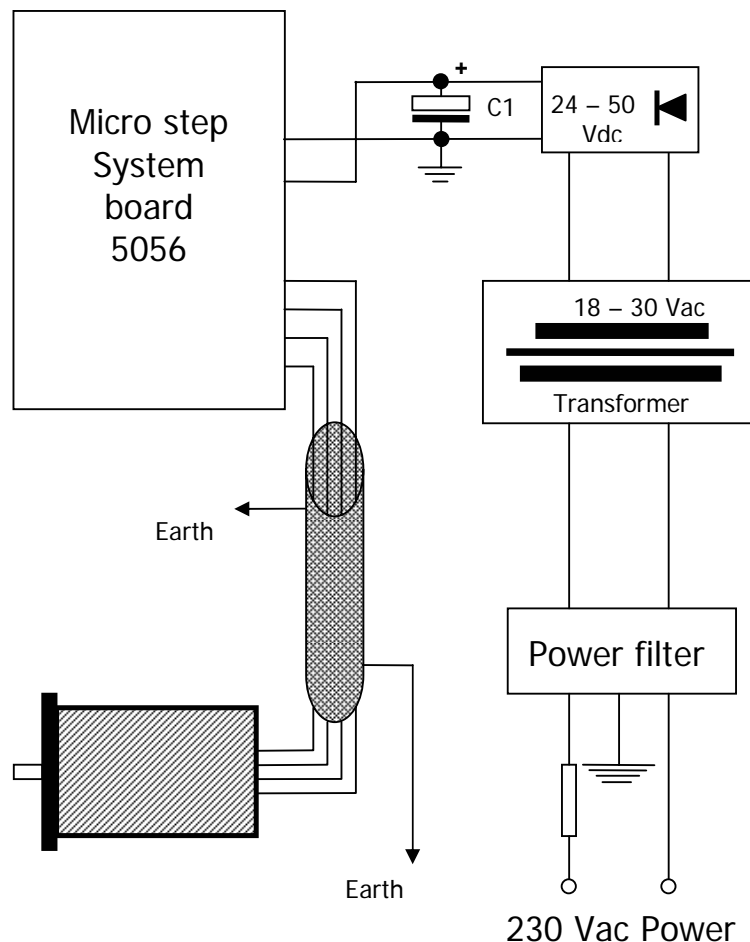

PIC. 1.

DamenCNC
Louis Pasteurweg 17
2408 AH Alphen aan den Rijn

E-Mail: kpdamen@damencnc.com
Homepage: <http://www.damencnc.com>