

1

2

3

4

5

6

RevNo	Revision note		Date	Signature	Checked
-------	---------------	--	------	-----------	---------

A

B

C

D

M5x0.7 Threaded hole

Ø15H7

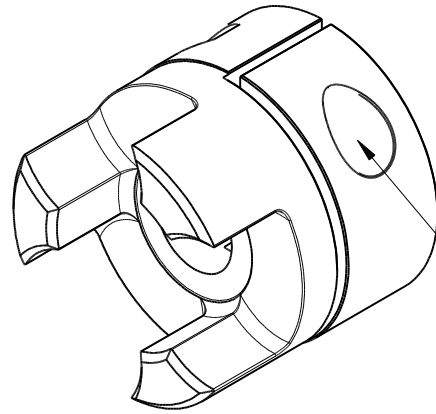
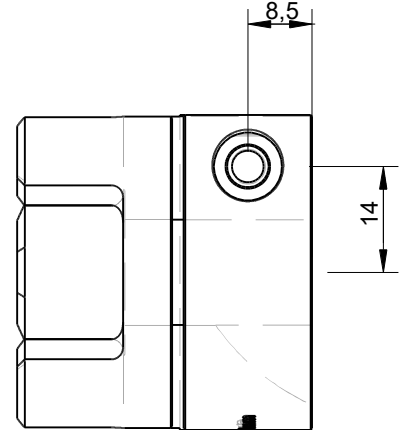
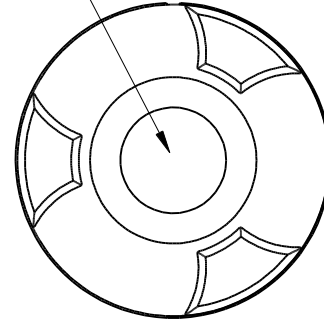
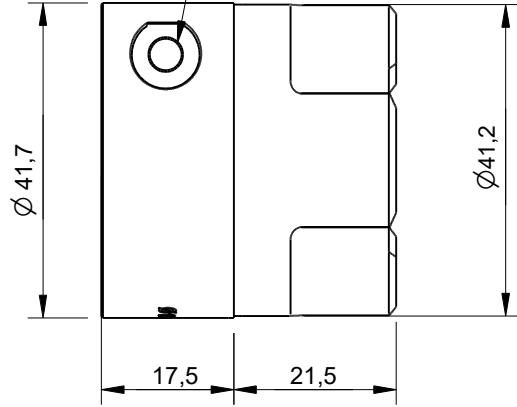

Pocket for bolt M5x16 DIN 912

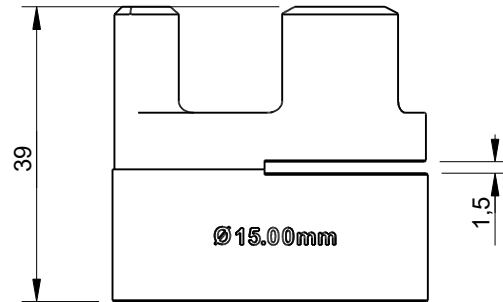

Units	mm
Tolerances	$\pm 0.1\text{mm}$ unless otherwise specified
Material	Alu 6082
Tumbling	Yes
Surface finish	None

Itemref	Quantity	Title/Name, designation, material, dimension etc			Article No./Reference	
Drawn by Kevin Damen	Checked by Rutger Schuit	Approved by - date 9-1-2026	File name	Date 9-1-2026	Scale	
<b>7507</b>			<b>www.damencnc.com</b>			
			7507 HUB ShaftCoupler DCNC-D40-L65-B15.00mm	Edition	Sheet	

1

2

3

4

5

6